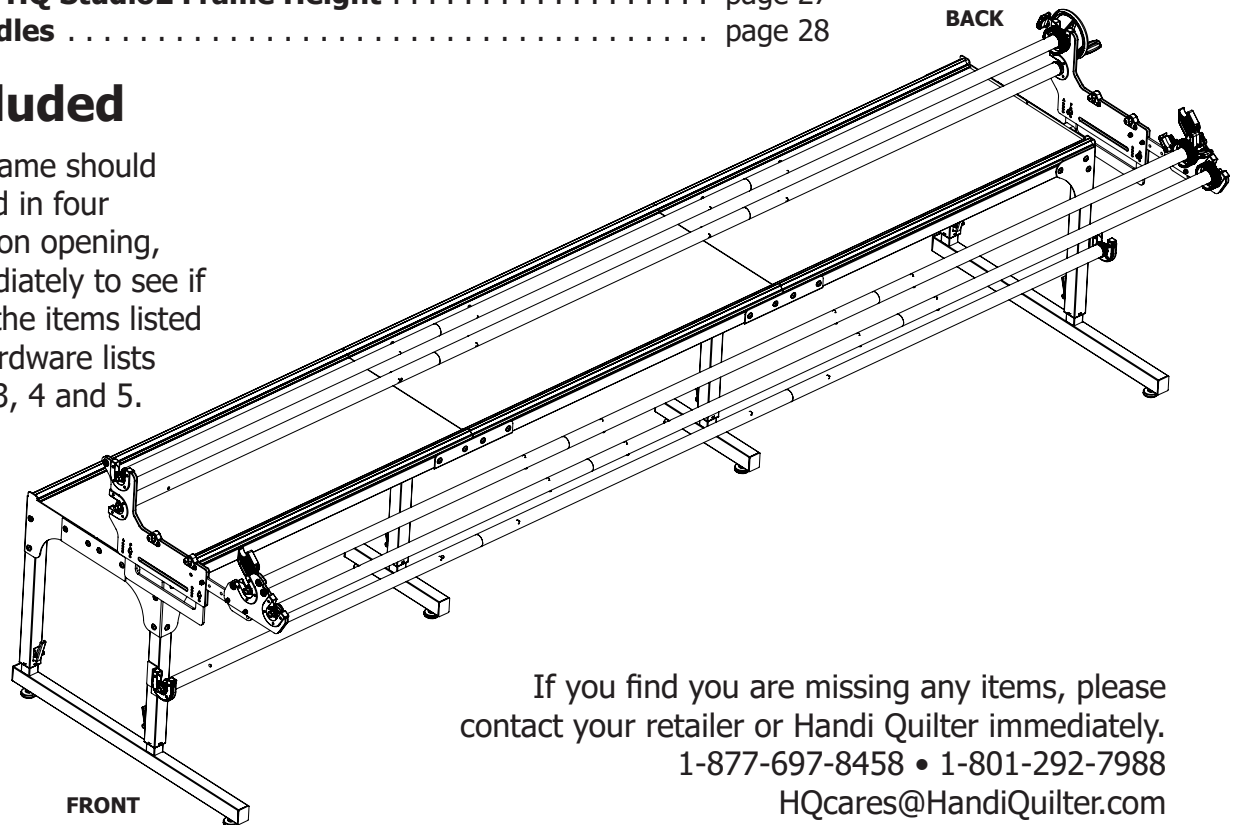

Table of Contents

Parts List	page 2
Hardware List	page 4
HQ Studio Frame Box Contents	page 5
Step 1: Frame Side Assembly	page 6
Step 2: Table Assembly	page 7
Step 3: Middle Leg Assembly	page 8
Step 4: End Leg Assembly	page 9
Step 5: Precision-Glide Track Assembly	page 12
Step 6: Front Pole Bracket to Back Pole Bracket Assembly	page 15
Step 7: Ratchet Stop Assembly	page 17
Step 8: Pole Bracket Assembly	page 19
Step 9: Pole Coupler Assembly	page 20
Step 10: Pole End Assembly (including Ratchet Wheel, Hand Wheel) . . .	page 21
Step 11: Pole to Frame Assembly	page 24
Step 12: Rubber End Cap Assembly	page 24
Step 13: Hook and Loop Strips Attachment	page 25
Step 14: Bungee Clamp Assembly	page 25
Step 15: Hook and Loop Strip Attachment	page 26
Step 16: Attaching Leaders	page 26
Step 17: Adjusting HQ Studio2 Frame Height	page 27
Using the Pole Cradles	page 28

What's Included

Your HQ Studio2 Frame should have been delivered in four separate boxes. Upon opening, please check immediately to see if you have received the items listed in the Parts and Hardware lists found on pages 2, 3, 4 and 5.



If you find you are missing any items, please contact your retailer or Handi Quilter immediately.
1-877-697-8458 • 1-801-292-7988
HQcares@HandiQuilter.com

HQ Studio2 Frame Parts List



Frame Side Coupler (2)
Box 3
Part# QF09318-01



Hook and Loop Strip (2)
Box 1
8" of Part# QF10613



12-foot Black Plastic Track (4)
Box 3
Part# QF09318-04

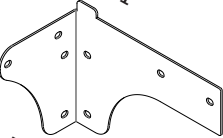

Right Frame Side Back (1)
Box 3
Part# QF09318-412

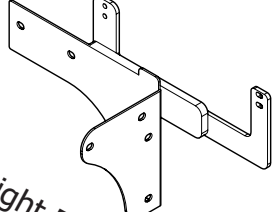

Right Frame Side Front (1)
Box 3
Part# QF09320-411

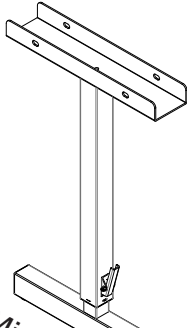

Middle Leg (2)
Box 3
Part# QF09318-600



Track Support Coupler (4)
Box 3
Part# QF09318-03

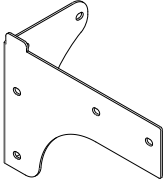

Left Frame Side Back (1)
Box 3
Part# QF09318-512

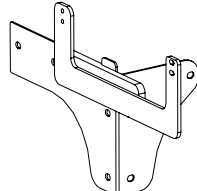

Left Frame Side Front (1)
Box 3
Part# QF09320-511

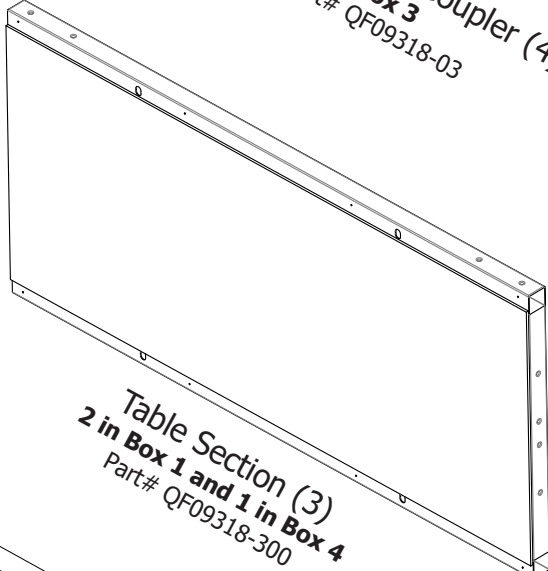
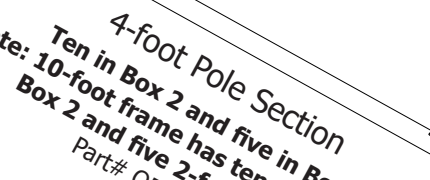
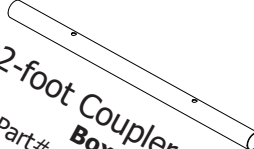

Table Section (3)
2 in Box 1 and 1 in Box 4
Part# QF09318-300



4-foot Pole Section
Ten in Box 2 and five in Box 4
(Note: 10-foot frame has ten 4-foot poles in Box 2 and five 2-foot in Box 4)
Part# QF09318-701



2-foot Coupler (10)
Box 2
Part# QF09318-702

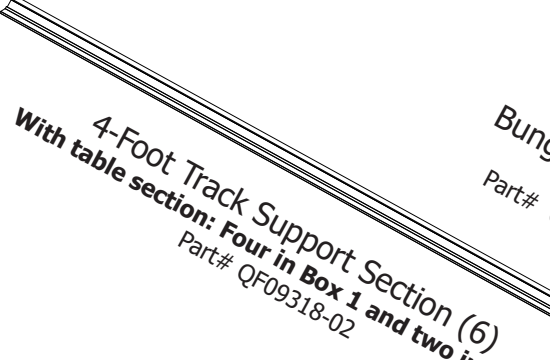

4-Foot Track Support Section (6)
With table section: Four in Box 1 and two in Box 4
Part# QF09318-02

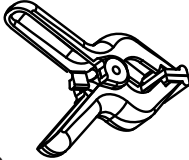

Bungee Clamp (4)
Box 3
Part# QF09318-110

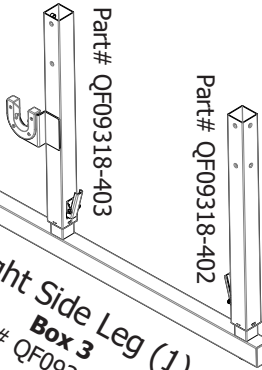

Right Side Leg (1)
Box 3
Part# QF09318-401

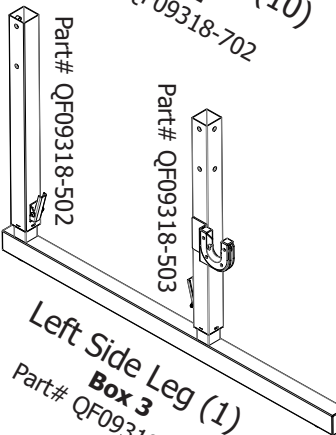

Left Side Leg (1)
Box 3
Part# QF09318-401

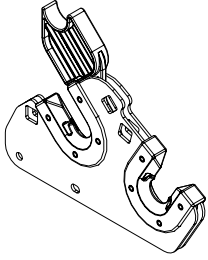

Table Splice Brace (4)
Box 3
Part# QF09318-05

HQ Studio2 Frame Parts List - Continued



Side Arm Assy Front Unplugged (1)

BOX 1
Part# QF12026-803

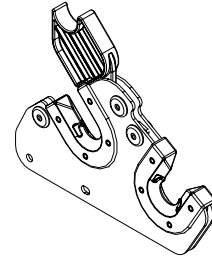

Side Arm Assy Front Plugged (1)

BOX 1
Part# QF12026-804

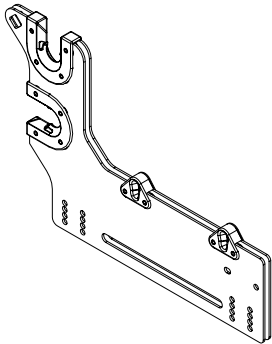

Side Arm Assy Rear Unplugged (1)

BOX 1
Part # QF09320-801

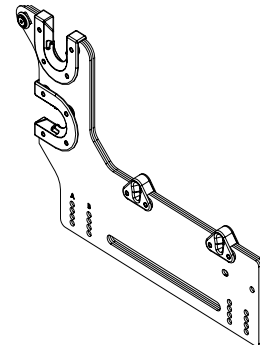

Side Arm Assy Rear Plugged (1)

BOX 1
Part# QF09320-802

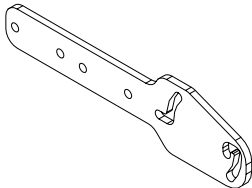

Connector Arm Studio 2 (2)

BOX 1
Part# QF09320-124

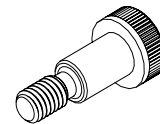

Screw M8 X 12 SKH Shoulder ZN (8)

BOX 3
Part# QF09320-07

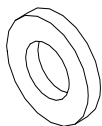

Washer M6 X 12 X 1.5 ZN (8)

BOX 3
Part# QM10642

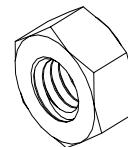

Nut M6 X 10 x 5mm ZN (8)

BOX 3
Part# QM10216

HQ Studio2 Frame Hardware List

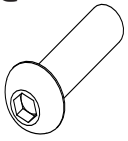

M8 x 25mm Socket Button Head Cap Screw (SBHCS) (4)
Part# QF09318-06

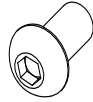

M8 x 16mm Socket Button Head Cap Screw (SBHCS) (64 total)
Part# QF09318-07

These parts found in Box #3

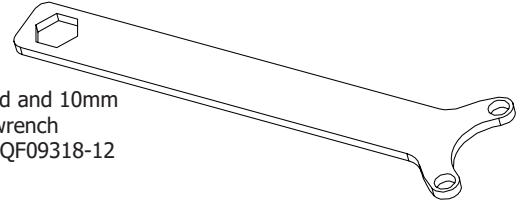

Pole end and 10mm wrench
Part # QF09318-12

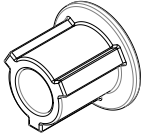

Hand Wheel Insert (1)
May be pre-assembled with Hand Wheel.
Part# QF09318-713



Rubber End Cap (10)
Part# QF09318-716



M8 Lock Nut (4)
Part# QF09318-08



M8 Flat Washer (4)
Part# QF09318-09



M6 x 12mm Connector Screw (12 total)
(8 in Box 1)
(4 in Box 4)
Part# QF09318-303



M5 x 8mm Socket Button Head Cap Screw (SBHCS) (24 total)
Part# QF09318-304

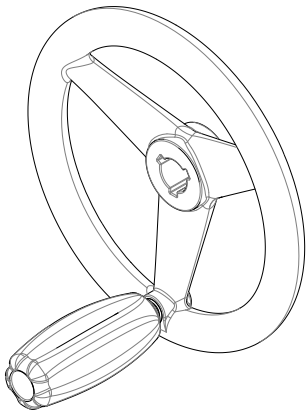

Hand Wheel Assembly (1)
Part# QF09325

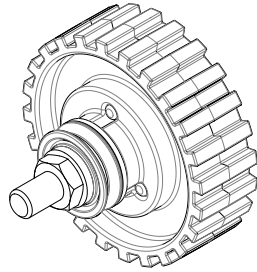

Short Bolt Ratchet Wheel Assembly (2)
Part# QF09320

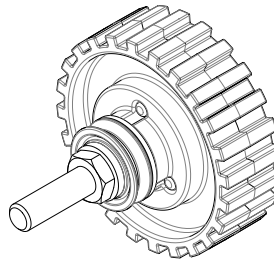

Long Bolt Ratchet Wheel Assembly (1)
Part# QF09321

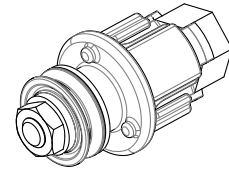

Pole End Assembly (7)
Part# QF09326

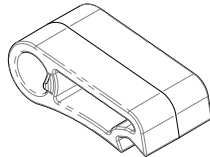

Ratchet-Stop (4)
Part# QF09318-203



Ratchet-Stop Mount (4)
Part# QF09318-202

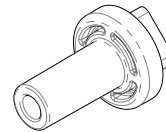

Ratchet-Stop Bushing (4)
Part# QF09318-201



Ratchet-Stop Holder (4)
Part# QF09318-205

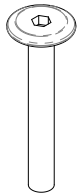

M6 x 48mm Connector Screw (4)
Part# QF09318-204

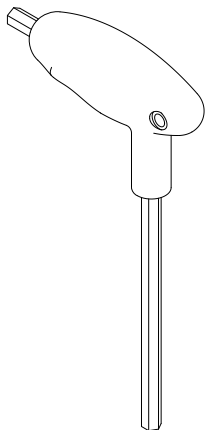

5mm Allen Wrench (1)
Part# QF09318-113

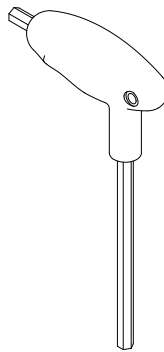

4mm Allen Wrench (1)
Part# QF09318-112

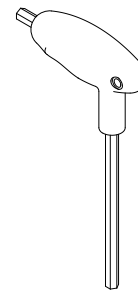

3mm Allen Wrench (1)
Part# QF09318-111



17/13/16mm Wrench (1)
Part# QF09318-114

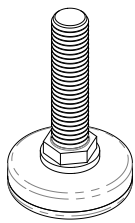

Leveling Foot (8)
Part# QF09318-108

HQ Studio2 Frame Box Contents

12-foot Frame (QF09320-12)

Box 1/4

- (2) 4-foot table sections
- (4) track supports
- (8) M6 X 12mm connector screw
- (1) left pole bracket
- (1) right pole bracket
- (1) Assembly instructions

Box 2/4

- (10) 4-foot poles
- (10) pole couplers

Box 3/4

All other parts (including plastic tracks)

Box 4/4

- (1) 4-foot table section
- (2) track supports
- (4) M6 X 12mm connector screw
- (5) 4-foot poles
- (3) 11-foot leaders
- (3) hook and loop tape

10-foot Frame (QF09320-10)

Box 1/4

- (2) 4-foot table sections
- (4) track supports
- (8) M6 X 12mm connector screw
- (1) left pole bracket
- (1) right pole bracket
- (1) Assembly instructions

Box 2/4

- (10) 4-foot poles
- (10) pole couplers

Box 3/4

All other parts (including plastic tracks)

Box 4/4

- (1) 2-foot table section
- (2) track supports
- (4) M6 X 12mm connector screw
- (5) 2-foot poles
- (3) 9 1/2-foot leaders
- (3) hook and loop tape

EXTRA PARTS NOTE: (Bag with 10 large washers and one 10mm regular nut)

The frame also has ten extra QF09318-706 Washers (1.19 X .646 x .075) washers (see pages 21-23 for image of large washer) and one 10mm regular nut (no part number). The nut is meant to be a tool for tightening the pole ends into the pole if one has trouble holding the pole end while trying to tighten the nyloc nuts onto the pole ends. One can also use the now provided QF09318-12 pole end tool (listed on page 4) to aid in this process. The regular nut can be used as a temporary tool over and over and is replaced by the permanent nyloc nut after the pole end is wedged into the pole. The extra washers are to be placed on the pole ends as needed if a pole is a little short, next to the other washer that size, making the pole fit better into the pole end support bearings. If the pole is short, and if the side arm pole supports are pushed in, to make the poles fit, they will put constant outward pressure on the pole ends to push them out of the pole.

Step 1: Frame Side Assembly

NOTE: Assembly is easiest if all connections are finger-tightened first as instructed, while assembling the frame. Tighten with the wrench only when instructed.

Why is this important? If you tighten as you go, you may have trouble getting all the parts to align properly.

NOTE: Make sure both height- adjustable legs are at their shortest setting before proceeding.

Remember that the batting bar bracket needs to be on the outside of the leg. (Fig. 1-1)

Parts Needed

- 1 - right side leg
- 1 - left side leg
- 1 - right frame side front
- 1 - left frame side front
- 1 - right frame side back
- 1 - left frame side back
- 4 - leveling feet
- 16 - M8 x 16mm SBHCS

Tools Required

- 5mm Allen wrench (provided)

1-1: Screw two (2) leveling feet about half way into the bottom of the left side leg, as shown in Fig. 1-1.

1-2: Attach the left frame side back onto the side leg using two M8 x 16mm SBHCS into the back of the back leg. Next install two more M8 x 16mm SBHCS into the side of the back leg. Finger-tighten the screws only for now. You will tighten the screws using an Allen wrench later in **Step 4.8**.

1-3: Attach the left frame side front onto the side leg using two M8 x 16mm SBHCS into the front of the front leg. Next install two more M8 x 16mm SBHCS into the side of the front leg. Finger-tighten the screws only for now. You will tighten the screws using an Allen wrench later in **Step 4.8**.

1-4: Using remaining parts, repeat **Steps 1-1** through **1-3** to complete the right side leg.

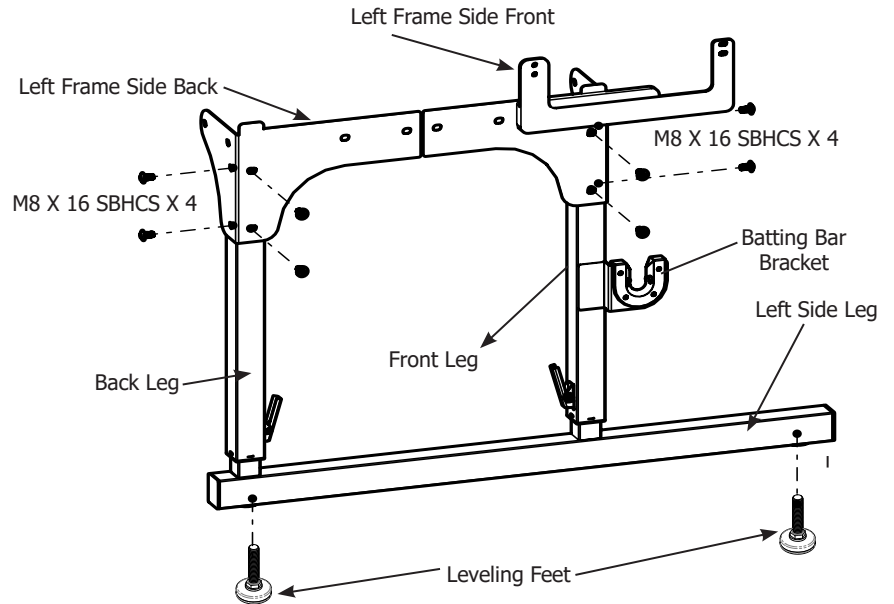

Fig. 1-1

Step 2: Table Assembly

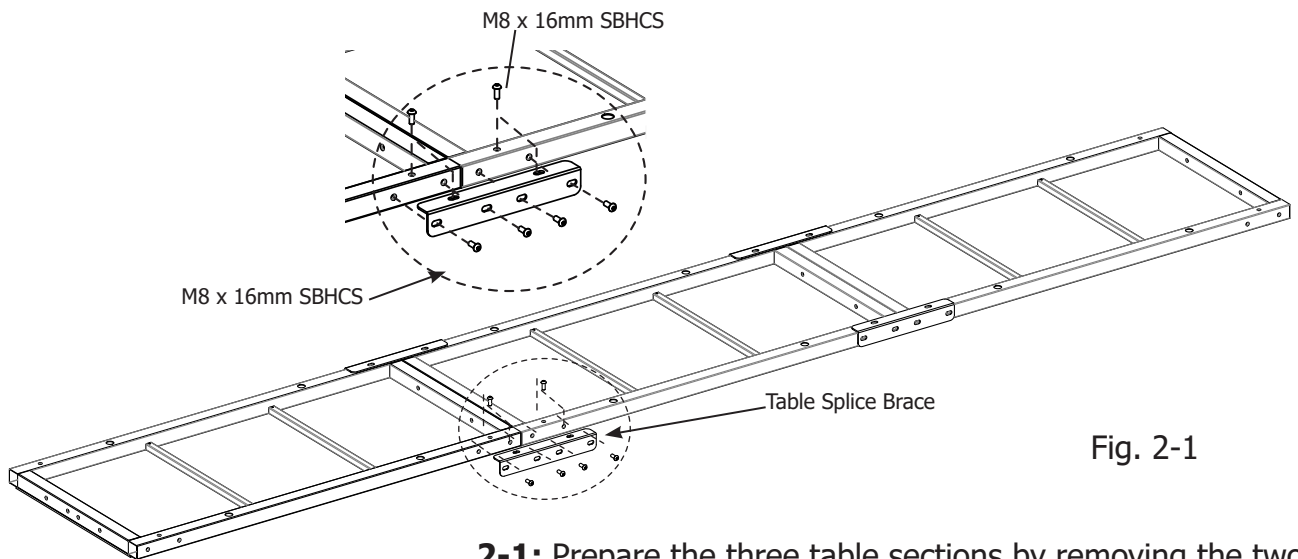

Fig. 2-1

Parts Needed

- 3 - table sections
 - 12-foot: three 4-foot sections
 - 10-foot: two 4-foot sections
one 2-foot section
- 4 - table splice brace
- 24 - M8 x 16mm SBHCS

Tools Required

- 5mm Allen wrench (provided)



NOTE: For this step, a carpeted surface is recommended for the protection of your floor and frame.

If you are working on a hard surface (such as tile, hardwoods or concrete), cover the surface with a blanket or rug.



NOTE: Skip **Steps 2 and 3** if you are setting the frame up at four feet. The 12-foot frame uses a 4-foot center/middle table section. **The 10-foot frame uses a 2-foot center/middle table section.**



NOTE: Remember to finger-tighten all screws first. Once all are in place, then tighten using the 5mm Allen wrench (provided) as instructed.

2-1: Prepare the three table sections by removing the two track supports screws from each track support. Set the track supports aside. These will be reinstalled in **Step 5** see Fig. 5-5. These were assembled on the table temporarily to protect them during shipping.

2-2: 12 foot: Start with two 4-foot table sections upside-down on the floor end to end. **10-foot:** start with one 2-foot and one 4-foot table sections upside-down on the floor, end to end (as shown in Fig. 2-1). Join the sections together by placing a table splice brace onto the sections, lining up the holes in the brace with those in the sections. Make sure the flange portion of the brace is on top (as shown).

2-3: Place four (4) M8 x 16mm SBHCS through the side of each table splice brace and **finger-tighten** them into the table sections.

2-4: Finger-tighten two (2) SBHCS through the top of each table splice brace (as shown). (Fig. 2-1)

2-5: Repeat **Steps 2-1** through **2-3** to add remaining 4-foot section. Important: For the 10-foot frame the 2-foot section goes in the center.

2-6: Pull the two table sections as close together as possible to remove the gap. (This will facilitate assembly of the middle legs in **Step 3**.)

2-7: Using the 5mm Allen wrench, tighten the four side screws on each table splice brace, until the brace touches the side of the table frames, and then loosen the screws $\frac{1}{2}$ turn.

2-8: Tighten fully the two (2) top screws on each table splice brace, using the 5mm Allen wrench. Now fully tighten the 4 screws on the side of each table splice brace. All 24 screws should now be tight.

Step 3: Middle Leg Assembly

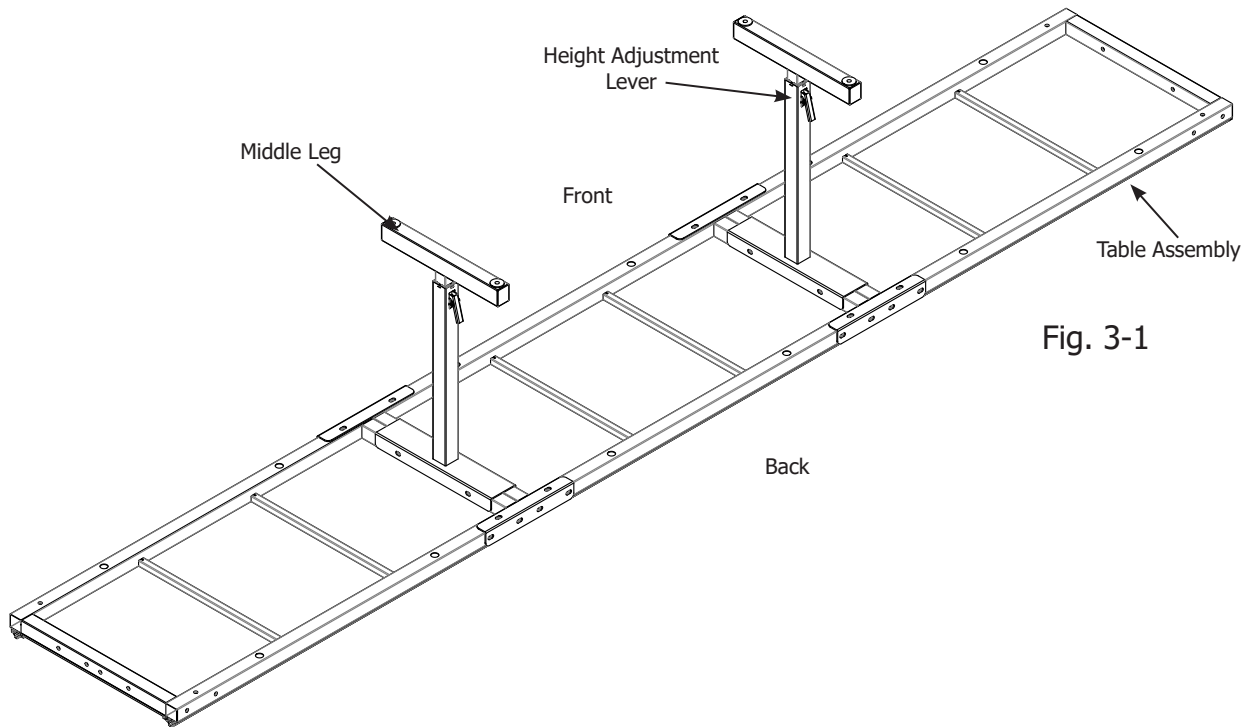

NOTE: If instructions were carefully followed in Section 2, there should be minimal gap between the table sections where the sections meet. The middle leg(s) should slide over the two table section end tubes easily. Check to ensure that all table splice brace screws are tightened before tightening the four middle leg screws.

Parts Needed

- 1 - table assembly
- 2 - middle legs
- 4 - leveling feet
- 8 - M8 x 16mm SBHCS

Tools Required

- 5mm Allen wrench (provided)

3-1: Install two (2) leveling feet about half way into one middle leg.

3-2: Place the middle leg assembly over two joined table sections. Attach the middle leg assembly using four (4) M8 x 16mm SBHCS.

3-3: While pushing down on the leg, fully tighten the four (4) screws.

NOTE: The direction the height adjustment levers face determine the back of the frame in this step.

3-4: Repeat **Steps 3-1** through **3-3** to attach remaining middle leg. Be sure middle leg assemblies are set at the lowest settings and that the height adjustment levers are facing in the same direction, towards the back of the table as shown in Fig. 3-1.

Step 4: End Leg Assembly

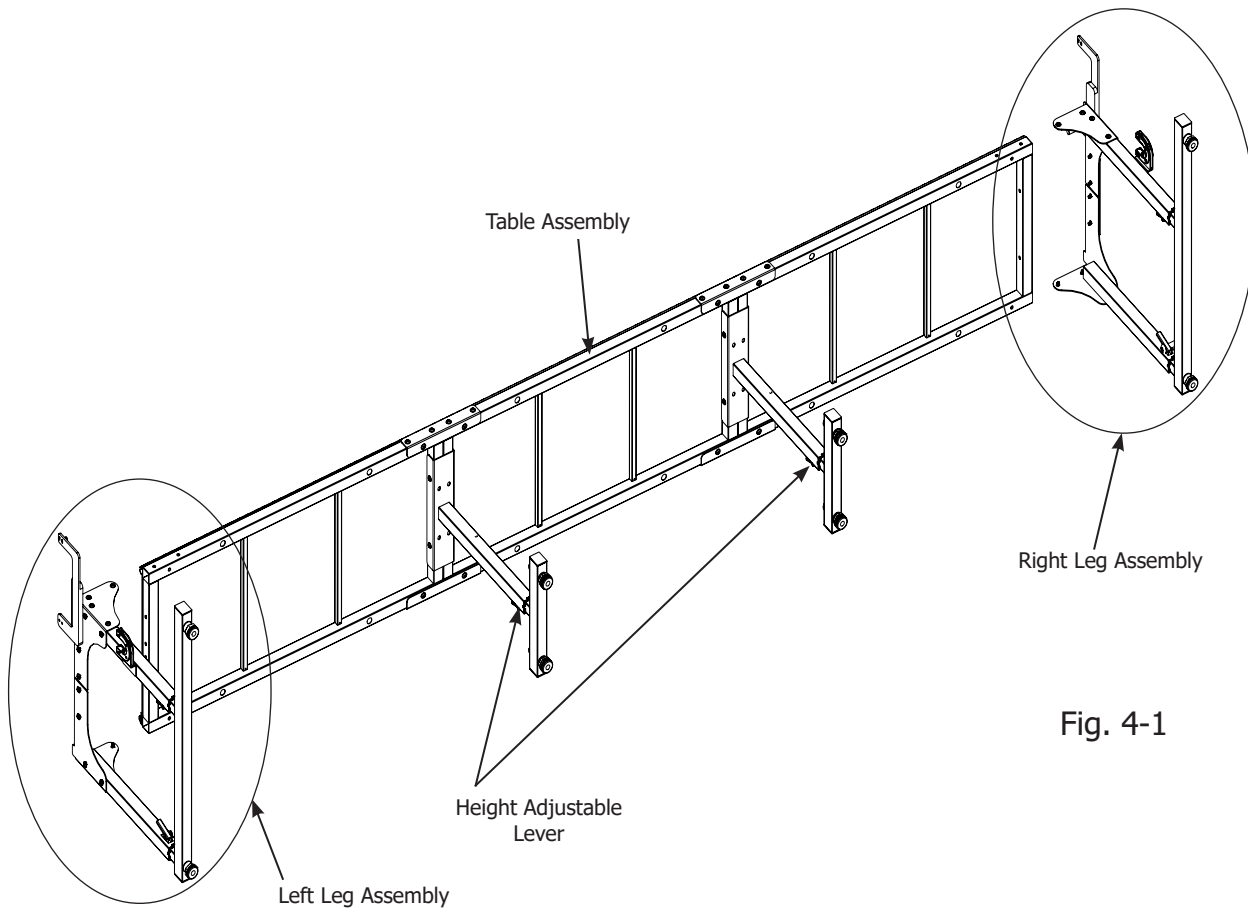



Fig. 4-1

 **NOTE:** Finger-tighten screws only until all screws are in place, they will be tightened after the table is turned up right. See **Step 4-8**.

Parts Needed

- 1 - table assembly
- 1 - right leg assembly
- 1 - left leg assembly
- 2 - frame side coupler
- 16 - M8 x 16mm SBHCS

Tools Required

- 5mm Allen wrench (provided)
- Spirit level (not provided)

4-1: In preparation for attaching the left and right leg assemblies to the frame, turn the frame on its side so the height adjustable levers are towards the ground, as shown in Fig. 4-1.

4-2: Slide the left leg assembly under the table assembly.

Step 4: End Leg Assembly (continued)



NOTE:
Make sure all height-adjustable legs are at their shortest setting before proceeding with **Step 4-6**.

4-3: Starting at the top left corner of table, screw two (2) M8 X 16mm SBHCS down through the top corner left frame side front piece into the table frame Fig. 4-2, **finger-tighten** only. (Fully tighten in Step 4-8)

4-4: Align the frame side coupler to the holes in the left frame side front and the left frame side back and screw four (4) screws thru the coupler, the frame side and into the table section Fig. 4-2.

4-5: Repeat **Steps 4-2** through **4-4** for the right leg assembly.

4-6: With the help of a second person, rotate the frame so it is standing in the upright position.

4-7: Place two (2) M8 x 16mm SBHCS each through the back side of the left and right leg assemblies, and **finger-tighten** only.

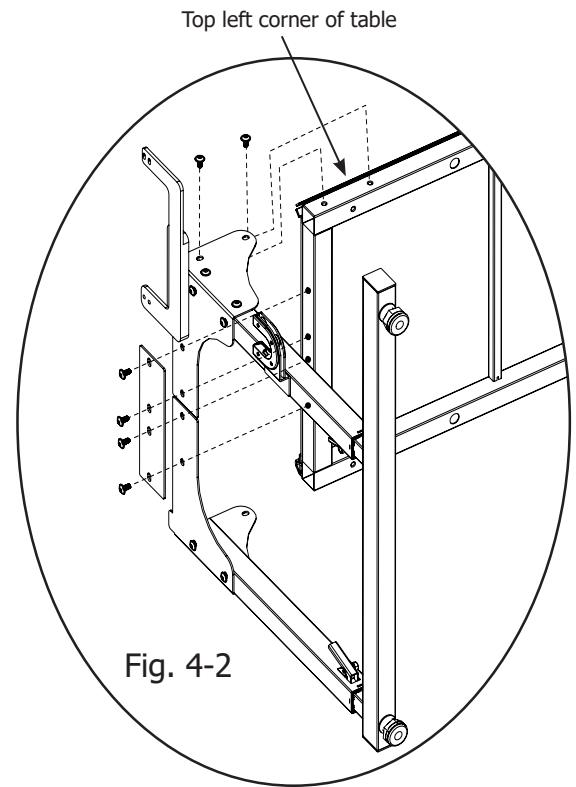
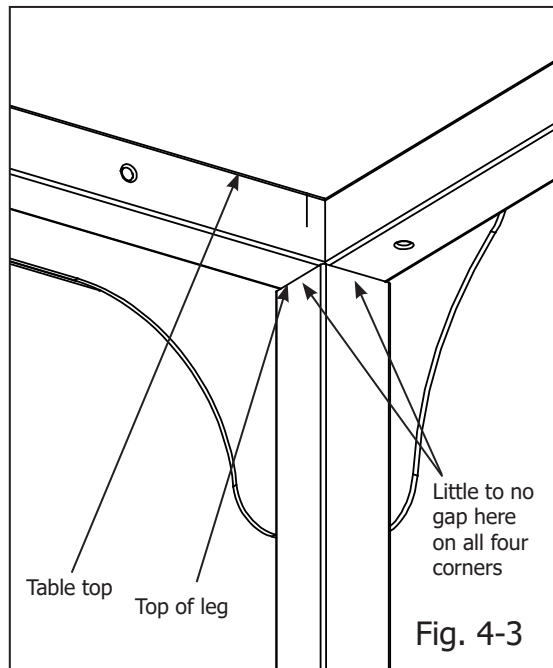

Fig. 4-2

Use M8 x 16mm
SBHCS here and
in all shown holes

Step 4: End Leg Assembly (continued)

4-8: Next, ensure that the table assembly is down on top of the left and right leg assemblies, at all four corners, by applying the appropriate pressure or support, (there should be little to no gap between the bottom of the table assembly and the top of each leg) see Fig. 4-3. Now using the 5mm Allen wrench, tighten the 4 screws at each corner to the table assembly (8 screws per end). Also tighten the 4 screws at each frame side to each leg at this time (8 more screws per end). If necessary have a second person help check and hold this while tightening the screws.



4-9: At this point, all screws should be tightened on the table. Double-check all M8X 16mm screws to make sure they are tightened, using the 5mm Allen tool.

4-10: Using a spirit level, check and adjust the frame top to be level, in the place where it will be used, both front to back and side to side, by adjusting the leveling feet. Double-check the table-top frame to ensure that it is flat at each table splice brace and not sagging or high at the joints (Fig. 4-4). If no spirit level is available, check the table with the machine on the carriage and the Precision-Glide tracks after they are installed in Step 5 and adjust appropriately. When the table is level, the machine should stay where you put it and not roll forward, back or side to side.

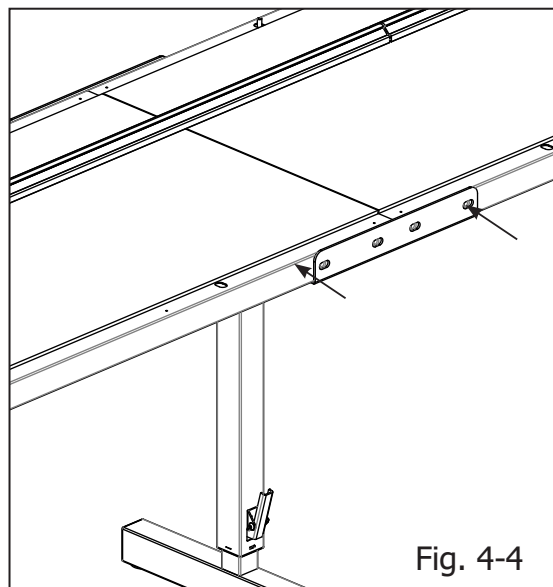

Step 5: Precision-Glide Track Assembly

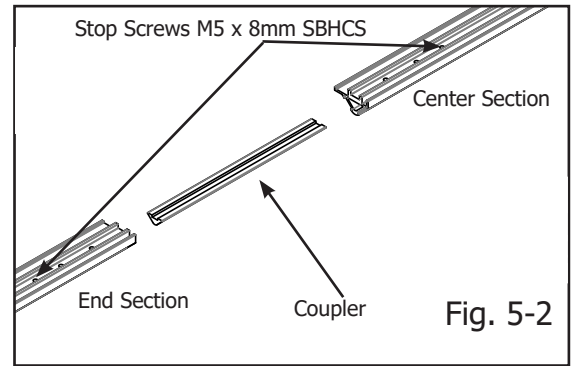
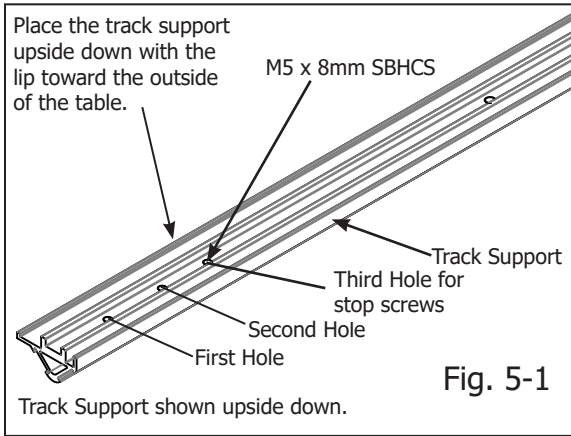

NOTE: The aluminum track support sections are cut from single sections of extruded aluminum and should align when placed end to end. However, if all directions in Step 5-4 are followed and track supports still do not align properly, try swapping track support sections, so that different ends are joining.

Parts Needed

- 1 - table
- 6 - track supports
 - 12 foot: 6 four foot supports
 - 10 foot: 4 four foot & 2 two foot
- 4 - track support couplers
- 24 - M5 X 8mm SBHCS
- 12 - M6 x 12mm connector screw
- 4 - 12' black plastic tracks

Tools Required

- 3mm Allen wrench (provided)
- 4mm Allen wrench (provided)

5-1: Check inside the ends of the track supports for burrs or debris and remove all foreign matter from the inside.

5-2: Lay three track-support sections on the table upside down, with the wider lip of the sections facing toward the outside of the table (Fig. 5-1).

5-3: To prepare for joining one end and the center support sections together, screw one M5X 8mm SBHCS into the third hole from each splice end of each section to serve as a stop screw (Fig. 5-1, Fig. 5-2). Fully tighten screw. This will help align the coupler properly into the two track support sections when joined.

5-4: Insert a coupler into one prepared end of one track support section up to the stop screw. Thread an M5 X 8 mm SBHCS into the first hole and lightly tighten as shown in Fig. 5-2. Insert the other end of the coupler into second prepared track support section. Hold the two adjoining track support sections tightly together and thread an M5 X 8mm SBHCS into the first hole of the second track support and lightly tighten (shown in Fig. 5-2). You may need to gently rock the track support to seat the coupler. Finally, insert a second screw into the track supports, align and tighten.

5-5: Repeat **Steps 5-3** and **5-4** to join remaining track support section to center track support section to assembly one (1) track support. Once alignment is assured, tighten all screws firmly.

Step 5: Precision-Glide Track Assembly (continued)

 **NOTE:** The extrusions have a wider shoulder on one edge of the track. This shoulder is to be placed toward the inside of the table over the edge of the black plastic tabletop. (Fig. 5.4)

 **NOTE:** The track support surfaces must be perfectly aligned. Otherwise, the quilter will feel a bump and quilting stitches will be adversely impacted.

5-6: Insert a plastic track completely into one side of the aluminum track supports. The plastic track should slide into the track support easily. If the plastic track binds slightly, try backing the track out a little, then pushing it further. If the plastic binds badly, check the track supports for debris, burrs, misalignment or damage. (Fig. 5-3) In same manner, insert plastic track in the other side of the track support.

5-7: Repeat **Steps 5-1** through **5-6** to make second track.

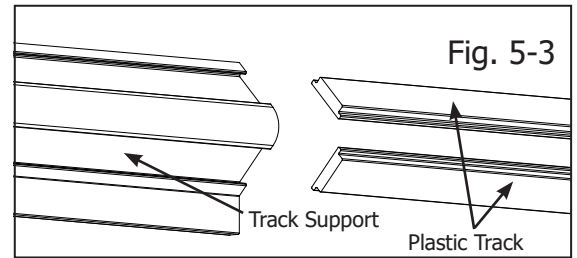

Fig. 5-5

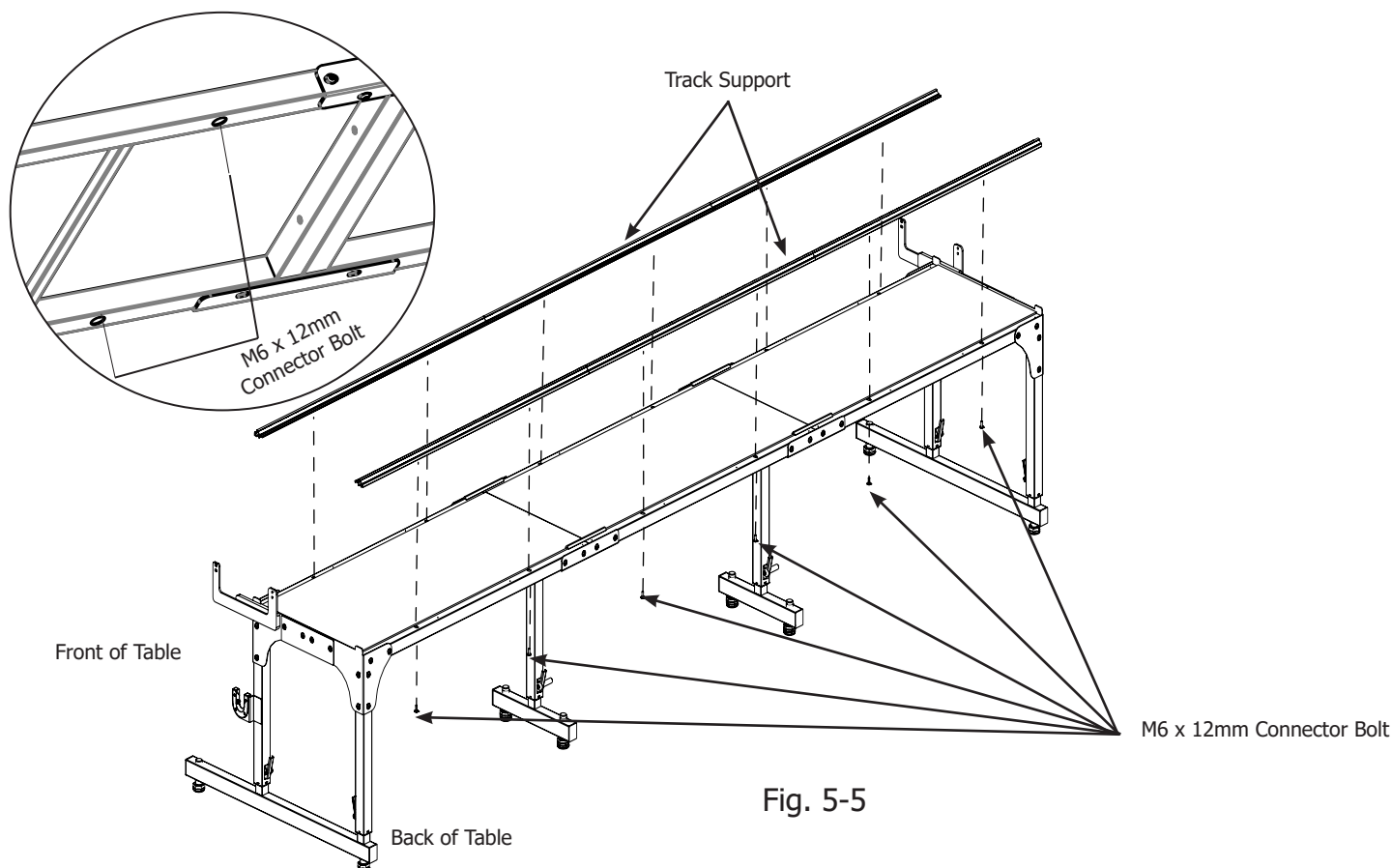

Fig. 5-5

5-8: Attach Tracks. Secure one assembled track to the back of the quilting frame. Line up the track support by holding it tightly against the plastic tabletop as you secure it to the frame, using six (6) M6 x 12mm connector screws, as shown in Fig. 5-5. **Do not tighten screws at this time.** They need to be loose to accommodate adjustments in **Step 5-9**. In same manner, attach the remaining track support to the front of the frame using six (6) M6 x 12mm connector bolts.

5-9: Align Tracks. Place the carriage on the tracks at one end of the table. Roll back and forth along the length of the table, establishing the distance between the two tracks, taking care to check that the wheels are engaging the track on both the front and the back of the carriage. Move both tracks in tandem to the back of table as far as possible. (Slots in the tables allow this movement.) Double-check that the back track is straight along the back edge of the table. Fully tighten the screws in the BACK track only for now.

5-10: Place the machine onto the carriage and again, roll it the entire length of the frame, working the tracks into the wheels as you go. Lightly tighten the front track support screws as you move down the table. Check the carriage to verify that it rolls smoothly and that both ends of the carriage are engaging the tracks. If you find a section of track where the carriage rocks back and forth when moved all the way forward or back, loosen the front track support screws, and adjust the front track until the carriage rolls smoothly and does not rock, then re-tighten the front track screws.

5-11: Finally, fully tighten the front track to the table.

Step 6: Front Pole Bracket to Back Pole Bracket Assembly

Parts Needed

- 1 - side arm assy front unplugged
- 1 - side arm assy front plugged
- 1 - side arm assy rear unplugged
- 1 - side arm assy rear plugged
- 2 - connector arm Studio 2
- 8 - screw M8 x 12 SKH shoulder ZN
- 8 - washer M6 X 12 X 1.5 ZN
- 8 - nut M6 X 10mm X 5mm ZN

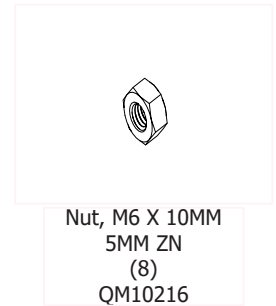
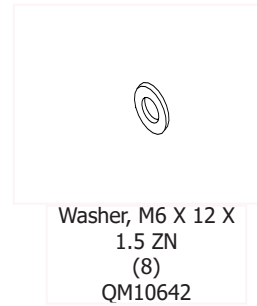

Tools Required

- 4mm Allen wrench (provided)
- 10mm wrench (provided)
- 13mm wrench (provided)

6-1: Identify the plugged and unplugged front and rear side arm assemblies.

 **NOTE:** Normally the unplugged assemblies are used on the right end of the frame. The unplugged assemblies go on the frame end where you want your handwheel and ratchet assemblies.

 **IMPORTANT:** For more information on how to decide whether the unplugged pole bracket will be on the right or left of the frame see **Step 7**.

6-2: Decide whether you want the frame to be set up for a 16-inch or 18-inch or 20-inch machine. The assembly and mounting are both different between the 16-inch or 18-inch and the 20-inch machines. See images on the next page for clarification.

 **NOTE:** The QF09320-07 M8 screw above has an 8mm shoulder and uses a QM10642, 6mm washer and QM10216 6mm nut.

6-3: For the 16-inch or 18-inch machines: The pole bracket needs to be assembled in the shorter configuration. Use the front two holes in the center connector arm for the front bracket and the next two holes for the back bracket. Align the holes and insert the four shoulder screws from the outside to inside so the threads will be on the inside when assembled. Then place the washer and Nyloc nut onto the screw. Fully tighten all four screws with the 10mm wrench and 4mm hex tool.

6-4: The front bracket can be moved into two positions so it needs to be adjusted with care. In step 6-3 the front two screws on the front bracket were fully tightened; now back them off about 1/2 turn, or until the front bracket can be set in both positions freely.

6-5: Repeat steps 6-1 through 6-4 for the plugged pole bracket assemblies.

Step 6: Front Pole Bracket to Back Pole Bracket - Continued

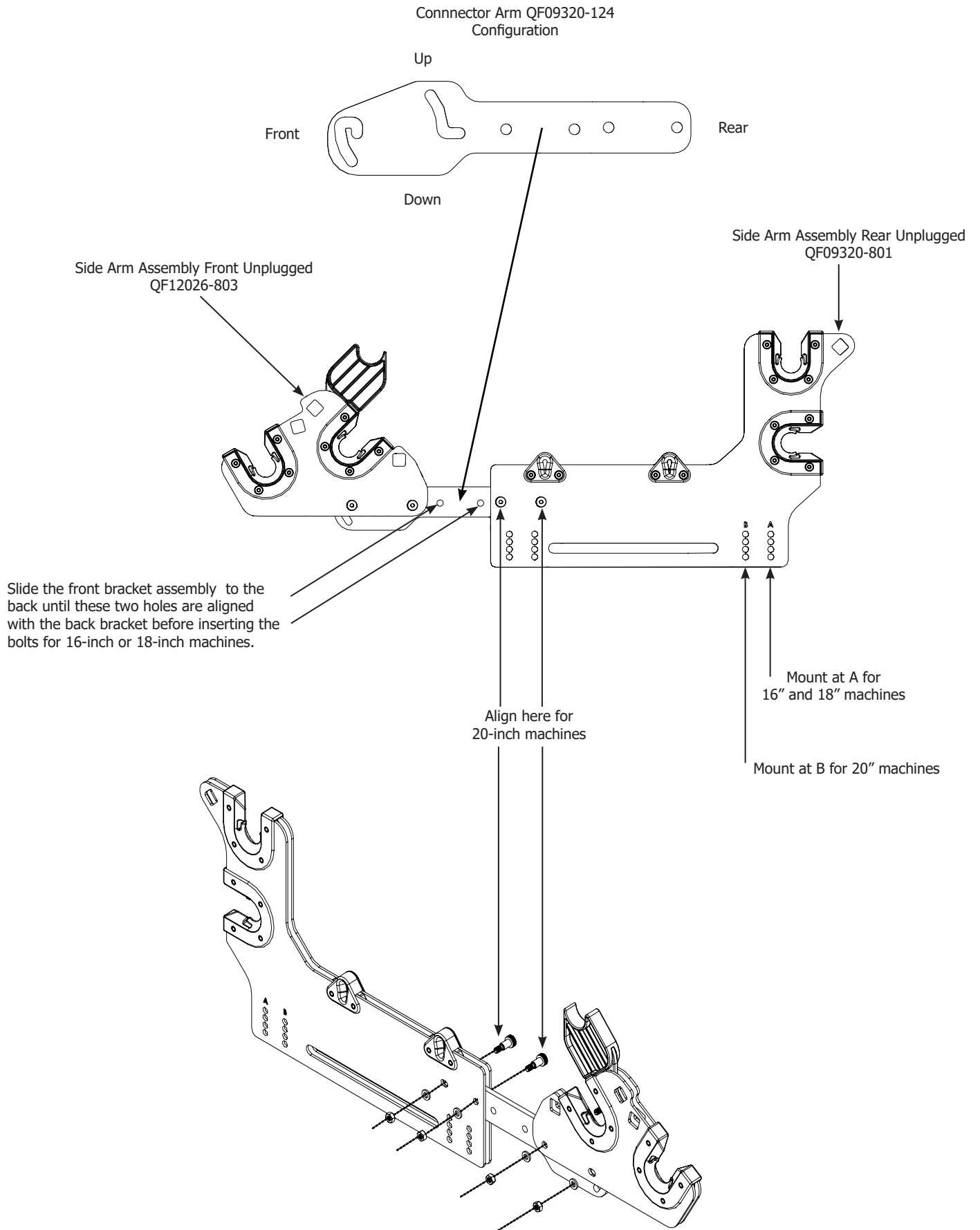

Step 7: Ratchet-Stop Assembly

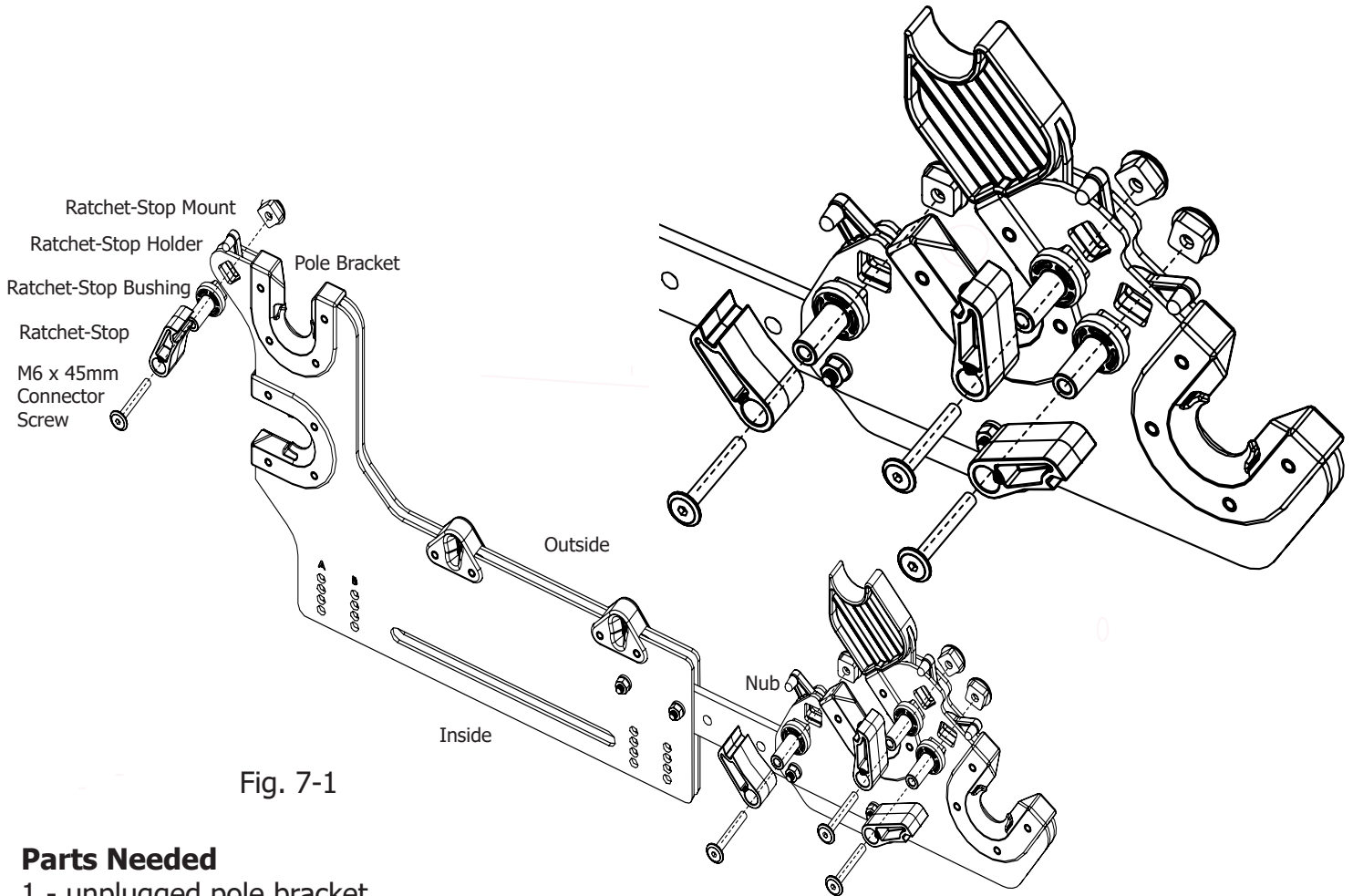

Fig. 7-1

Parts Needed

- 1 - unplugged pole bracket
- 4 - M6 x 45mm connector screw
- 4 - ratchet-stop
- 4 - ratchet-stop bushing
- 4 - ratchet-stop mount
- 4 - ratchet-stop holder

Tools Required

4mm Allen wrench (provided)

7-1: Decide whether you want the ratchets and hand wheel to be on the left or the right side of the frame. The following instructions show how to assemble the frame with the hand wheel on the right side of the frame, which is the most common setup. If you prefer the hand wheel to be on the left side of the frame, see "Left Side Option" on the next page.

7-2: Identify the unplugged pole bracket and the plugged-hole pole bracket. The plugged hole pole bracket can be used "as-is" on either the left or right side, depending on the decision made about which side the hand wheel will be on. Set the plugged-hole pole bracket aside at this time.

The ratchet stops and ratchet-stop holder will be assembled into the unplugged pole bracket, but the orientation of the stops and holders will vary, depending upon whether the pole bracket is used on the right or the left side of the table. The instructions that follow assume that the open-pole bracket (and hand wheel) will be used on the right side of the frame.

Step 7: Ratchet-Stop Assembly (continued)

7-3: Place one ratchet-stop holder between the two metal pieces at the back of the unplugged pole bracket, with the stop nub facing inside, as shown in Fig. 7-1. If the ratchet-stop holder will not fit, loosen the two pole-bearing screws nearest the square hole. Slide in the ratchet-stop holder and re-tighten when finished.

7-4: Following the parts order in the circled detail in Fig. 7.1, thread one M6 x 45mm connector screw through a ratchet stop, ratchet-stop bushing, pole bracket (with ratchet-stop holder inserted) and finally into the ratchet-stop mount. Pay close attention to the orientation of the ratchet stop. Tighten with the 4mm Allen tool until the ratchet-stop holder nub holds the ratchet stop.

7-5: In same manner, attach the remaining ratchet stops and ratchet-stop holders to the front of the pole bracket, paying attention to the orientation of the ratchet stops (Fig. 7-1) to create the right pole bracket.

Left Side Option

If assembling with the hand wheel and ratchets on the left side, remember that the ratchet stops and the ratchet-stop holder nubs go to the inside of the pole bracket when it is attached to the table. Keeping this in mind, follow **Steps 7-2** through **7-5** to assemble the left pole bracket, reversing the direction of the ratchet-stop, ratchet-stop bushing, ratchet-stop holder and ratchet-stop mount shown in Fig. 7-1.

Step 8: Pole-Bracket Assembly

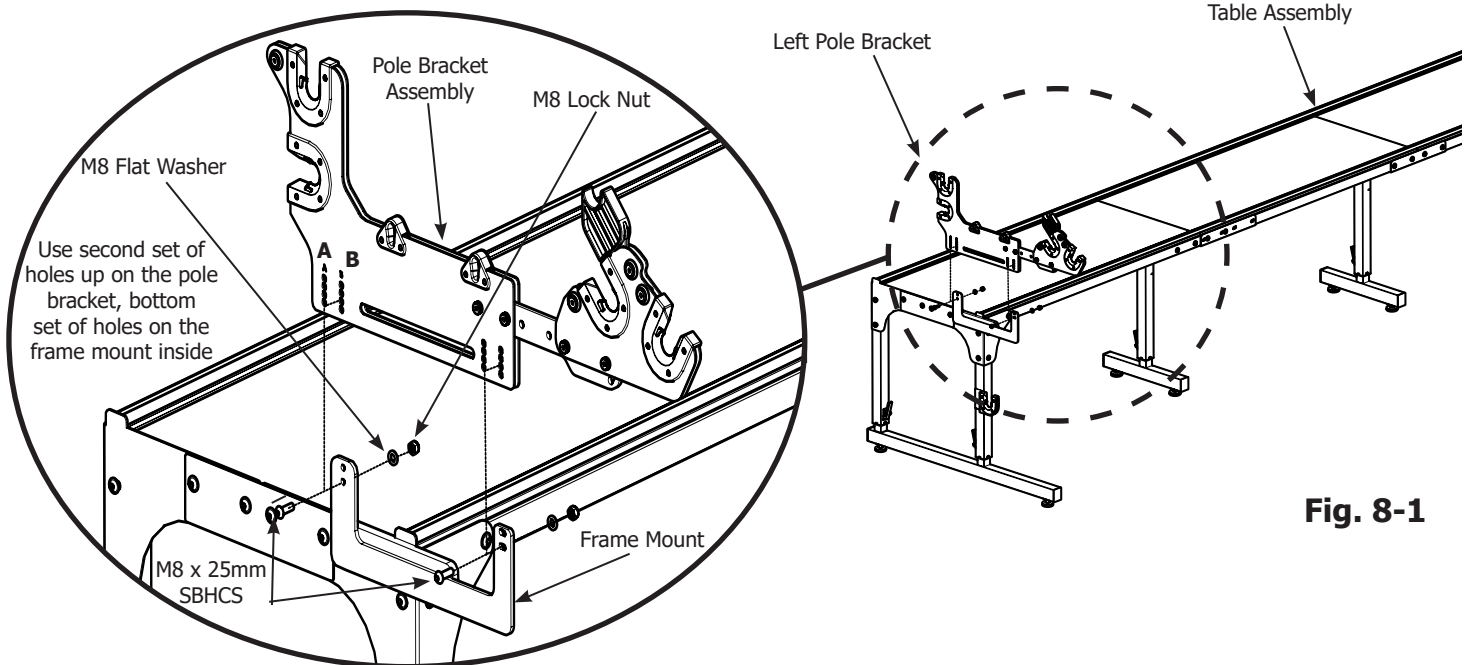

Fig. 8-1

NOTE: If setting frame up with hand wheel on the left side of frame, reverse position (switch sides) of pole brackets.

Parts Needed

- 1 - table
- 1 -unplugged pole bracket w/ratchet-stops assembly
- 1 - plugged-hole pole bracket
- 4 - M8 x 25mm SBHCS
- 4 - M8 flat washer
- 4 - M8 lock nut

Tools Required

- 13/17 mm wrench (provided)
- 5mm Allen wrench (provided)

8-1: Observe these items first:

- a. **For 20-inch machines:** Align the B set of holes on the pole bracket assembly with the frame mount
- b. **For 16 or 18-inch machines:** Align the A set of holes on the pole bracket assembly with the frame mount.
- c. **Use the bottom set of holes on the frame mount**
- d. **Use the 2nd set of holes up on the pole bracket assembly**

8.2: Slide the plugged-hole pole bracket down over the metal frame mount on the left frame side front. The pole bracket should straddle the frame mount. Attach the plugged-hole pole bracket to the frame using two (2) M8 x 25mm SBHCS. Align the screws through the second hole from the bottom of the pole bracket into the bottom hole on the frame mount and insert the screws from the outside to the inside of the frame. On the end of each screw, slide a flat washer followed by a lock nut, as shown in Fig. 8-1.

8-3: Visually level the pole bracket assembly and fully tighten the two screws using the 13/17 mm wrench and the 5mm Allen wrench provided.

8-4: Repeat **Step 8-1** and **Step 8-2** to attach the unplugged pole bracket with ratchet stops assembly, making sure the ratchet stops are on the inside of the frame.

Step 9: Pole Coupler Assembly

IMPORTANT: Be careful not to pinch your hands between pole parts while sliding them together.

NOTE: Your frame comes with 15 pole sections, which enable you to create 5 completed pole assemblies (the 4-foot size uses five pole sections, 8-foot uses 10 pole sections and 5 couplers, and the 12-foot uses all 15 pole sections and all 10 couplers).

NOTE: If you are assembling a four-foot (4-foot) frame, you may skip **Step 8** and proceed to **Step 9**.

NOTE: 10-foot frame uses 10 four-foot pole sections and 5 two-foot pole sections. The two-foot sections go in the center.

NOTE: Instructions are for assembling 12-foot pole assemblies using three 4-foot pole sections for each of five poles. See alternate instructions for different size frames below:

4-foot frame: Skip **Step 9** and proceed to **Step 10**.

8-foot frame: Use two 4-foot pole sections for each of five poles.

10-foot frame: Use two 4-foot and one 2-foot pole section for each of five poles. Place the 2-foot pole section in the center of the final pole assembly.

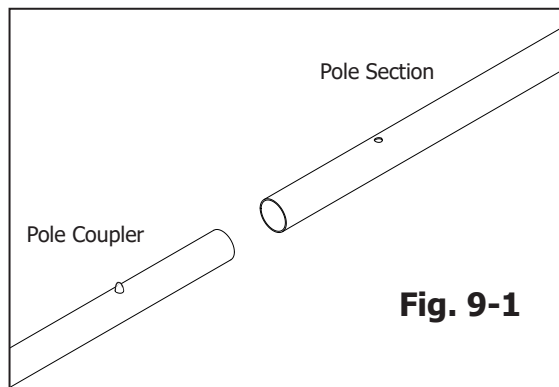

Fig. 9-1

Parts Needed

15 pole sections
10 pole couplers

9-1: Join two 4-foot pole sections together by inserting a pole coupler into the end of one pole section (as shown in Fig. 9-1), depressing the spring button as it slides in. Continue sliding until the spring button pops out of the hole in the pole section. Repeat to add second 4-foot pole section to the first.

9-2: In same manner, add final 4-foot pole section to section completed in **Step 9-1** to complete one 12-foot pole assembly.

9-3: Using remaining couplers and pole sections, repeat **Steps 9-1** and **9-2** to complete four more 12-foot pole assemblies for a total of 5 pole assemblies.

Step 10: Pole End Assembly

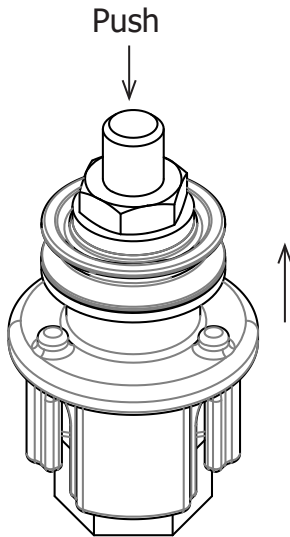

Fig. 10-1

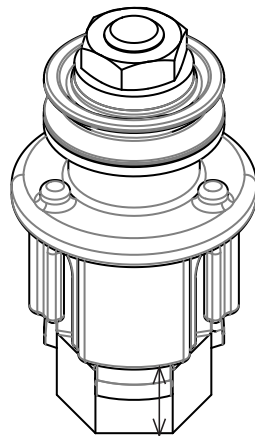

Fig. 10-2

Parts Needed

- 5 - pole assemblies
- 7 - pole ends
- 2 - short-bolt ratchet wheel assemblies
- 1 - long-bolt ratchet wheel assembly
- 1 - hand wheel

Tools Required

- 13/17 mm wrench (provided)

Pole End Assembly

10-1: Check one pole end to ensure that it matches Figs. 10-1 and 10-3.

10-2: Loosen the nut on the pole end until it nearly reaches the end of the bolt.

10-3: Holding onto the outside pole end, push the nut end of the bolt towards the opposite end of the assembly, until the inside pole end short bolt wedge slides out (Fig. 10-2). This makes the outside diameter of the pole end narrower and ready to be inserted into the end of the pole assembly.

10-4: Repeat **Steps 10-1** through **10-3** to prepare the remaining 6 pole ends for insertion.

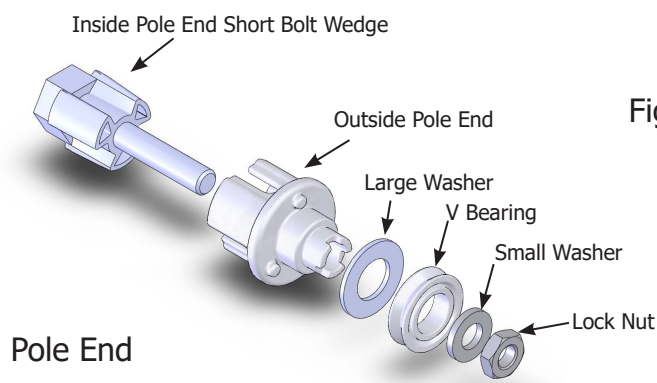

Fig. 10-3

Pole End assembly comes pre-assembled. Exploded diagram is for reference only.

Step 10: Pole End Assembly (continued)

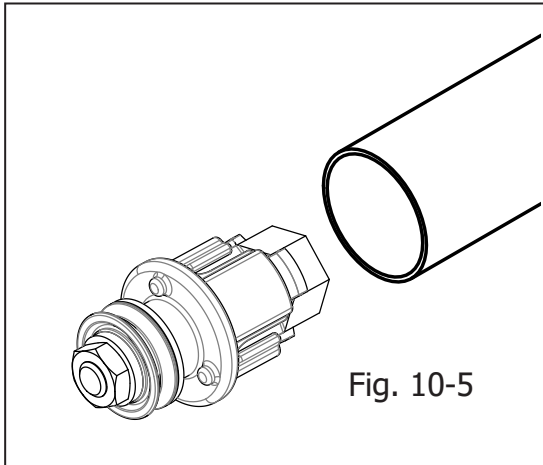

Fig. 10-5

10-5: Slide one pole end into the end of one 12-foot pole assembly, as shown in Fig. 10-5. Check that the pole end is inserted completely into the pole assembly.

10-6: Completely tighten the nut, using the 13/17mm wrench, while holding the pole end assembly tightly into the open end of the pole. This will expand the outer pole end, ensuring a tight fit in the pole.

NOTE: A regular nut is provided as an assembly aid tool if you have difficulty holding the pole end assembly while tightening.

10-7: Repeat **Steps 10-5** and **10-6** to add one pole end to the remaining four pole assemblies.

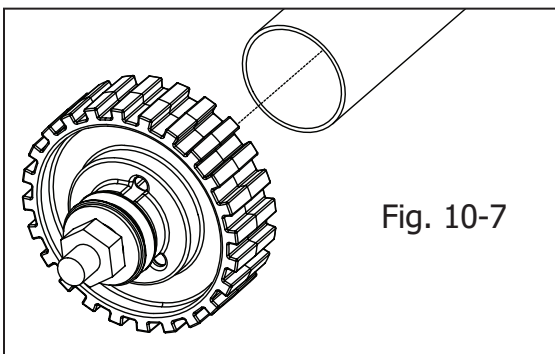

Fig. 10-7

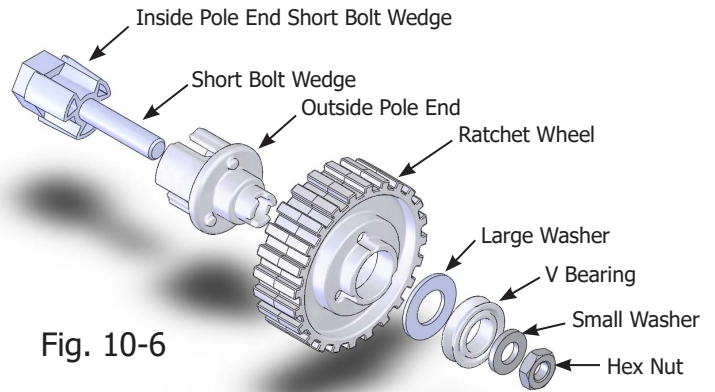

Fig. 10-6

Short-bolt ratchet assembly comes pre-assembled. Exploded diagram is for reference only.

10-8: Repeat **Steps 10-5** and **10-6** to add remaining two pole ends to the open ends of two pole assemblies (see bottom pole in Fig. 10-8). Set these two completed poles aside for use as the batting storage pole and the idler pole.

Short-Bolt Ratchet-Wheel Assembly

10-9: Check the short-bolt ratchet-wheel assembly to ensure that it matches Fig. 10-6.

10-10: Loosen the nut at the end of the short-bolt ratchet-wheel assembly until it nearly reaches the end of the bolt.

10-11: Holding onto the outside pole end, push the nut end of the bolt towards the opposite end of the assembly until the inside pole-end short-bolt wedge slides out (in similar fashion to **Step 10-3**). This makes the outside diameter of the outside pole end narrower and ready to be inserted into the end of a pole assembly.

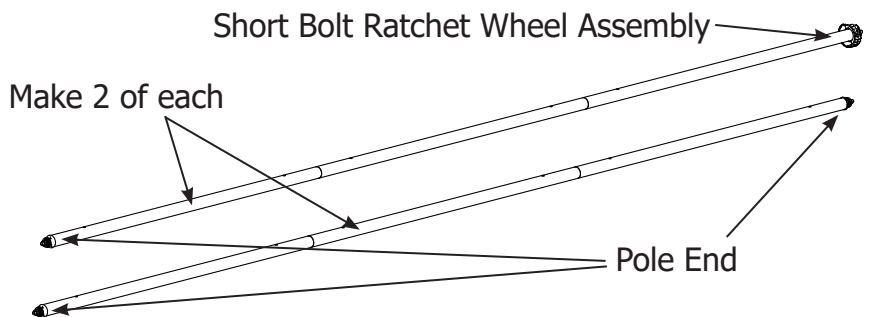

Fig. 10-8

Step 10: Pole End Assembly (continued)

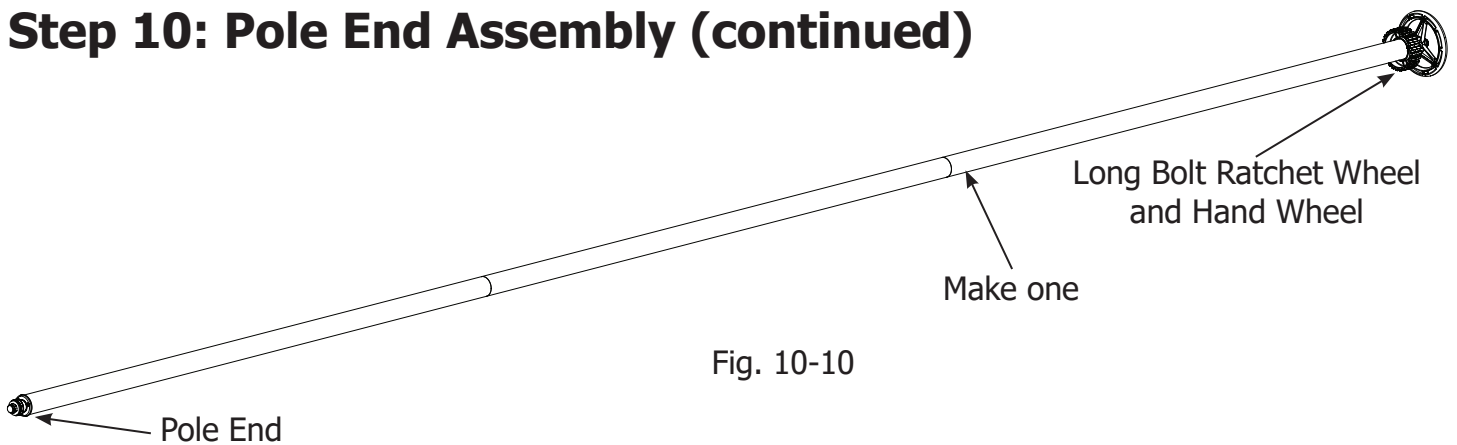
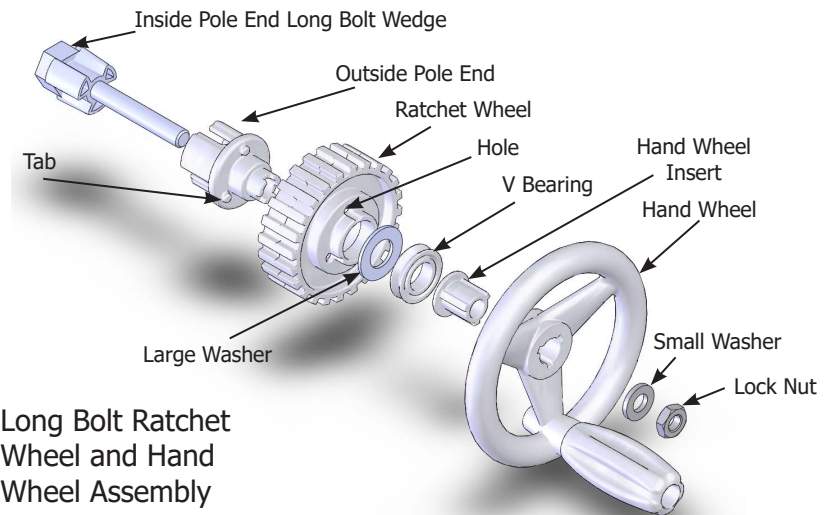

Fig. 10-10

Hand Wheel Assembly

10-12: Check the long-bolt ratchet-wheel assembly to ensure that it matches Fig. 10-9.

10-13: Add the hand wheel assembly to the long-bolt ratchet-wheel assembly as shown in Fig. 10-9, aligning the three tabs on the hand-wheel insert with the three notches on the outside pole end. If the three tabs are not properly aligned, the hand wheel will spin freely, independent of the pole. The goal is to have the three tabs engaged, so turning the hand wheel will turn the pole.



Long Bolt Ratchet Wheel and Hand Wheel Assembly

Long bolt ratchet wheel comes pre-assembled. Exploded diagram is included for reference.

Fig. 10-9

10-14: Repeat **Step 10-11** to prepare the long-bolt ratchet wheel and hand wheel assembly for insertion.

Ratchet Wheel and Hand Wheel Insertion

10-15: Insert one short-bolt ratchet wheel assembly into the open end of a pole assembly as shown in Fig. 10-7 on page 21. Check that the pole end is inserted completely into the pole assembly.

10-16: Completely tighten the nut, using the 13/17 mm wrench, while holding the short-bolt ratchet-wheel assembly tightly into the open end of the pole. This will expand the outer

pole end, ensuring a tight fit in the pole. Make sure the 3 tabs on the outside pole end align with the 3 holes in the ratchet wheel, see Fig 10-9. This completes the backing pole.

10-17: Repeat **Steps 10-15** and **10-16** to complete the quilt-top pole. Set both poles aside.

10-18: In same manner, slide the long-bolt ratchet wheel and hand wheel assembly into the open end of the remaining pole assembly and while holding the complete assembly tightly into the open end of the pole tighten the nut, using the 13/17 mm wrench. Check to be sure the hand wheel engages the ratchet wheel assembly and does not spin loosely and that the 3 tabs of the outside pole end align with the 3 holes in the ratchet wheel. This completes the take-up pole.

Steps 11: Pole to Frame Assembly

Parts Needed

- 1 - frame assembly
- 1 - batting storage pole
- 1 - idler pole
- 1 - quilt-top pole
- 1 - backing pole
- 1 - take-up pole

11-1: Place the poles on the frame, as shown in Fig. 11-1.

 **NOTE:** The poles will snap past the plastic fingers, which are shown in Fig. 11-2.

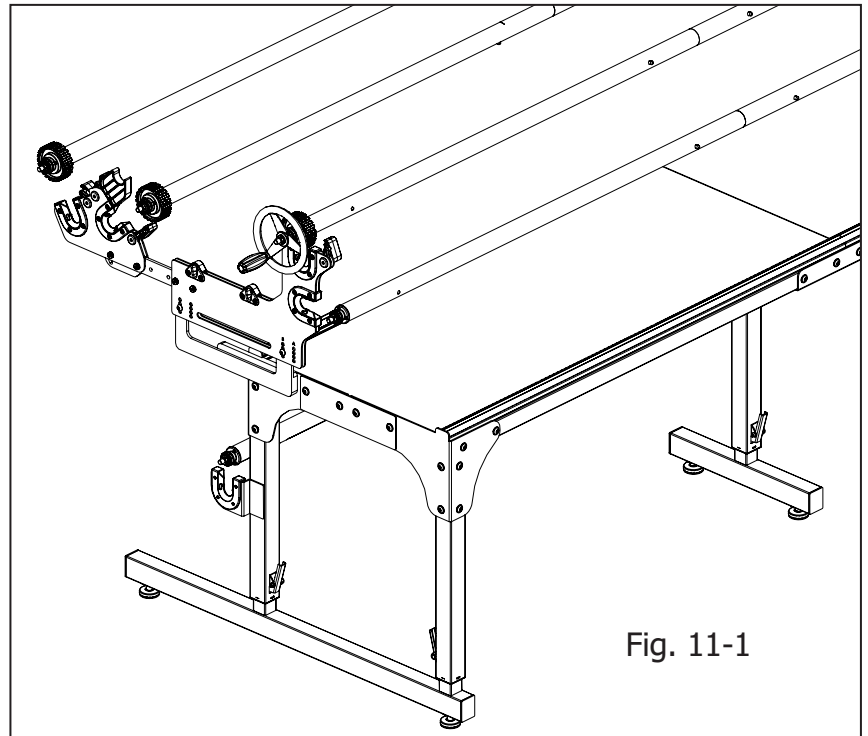

Fig. 11-1

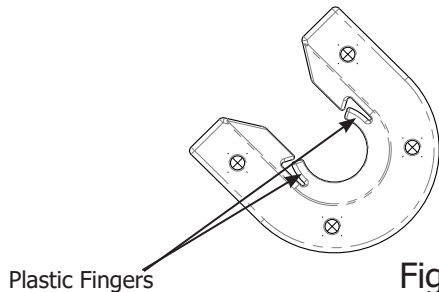

Fig. 11-2

Step 12: Rubber End Cap Assembly

Parts Needed

- 1 - frame assembly
- 10 - rubber end caps

12-1: Slide one (1) rubber end cap onto the end of each bolt sticking out of the pole ends, as shown in Fig. 12-1. If the poles are assembled properly, there should be approximately 3/8 - 1/2-inch of metal threads showing beyond the ends of each pole.

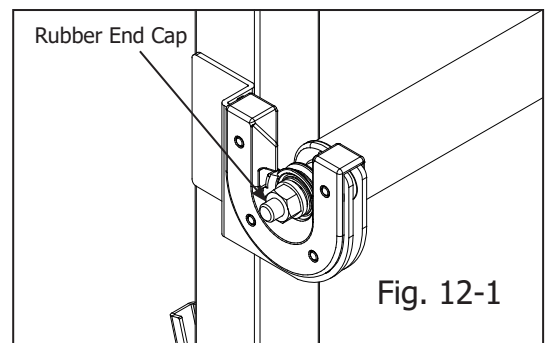

Fig. 12-1

Steps 13: Optional Hook and Loop Attachment Assembly

Parts Needed

- 1 - frame assembly
- 2 - hook and loop strip

13-1: Cut three pieces of hook and loop strip to fit as shown above. If the frame is set up for a 16-inch or 18-inch machine, only two pieces will be needed. Start from one side of the hook and loop strip and remove about 1/2 of the protective paper and then place the sticky side right below the bungee clamps and press the hook and loop strip firmly to the frame. Remove the remainder of the protective paper and press the hook and loop strip down. (Fig. 13-1)

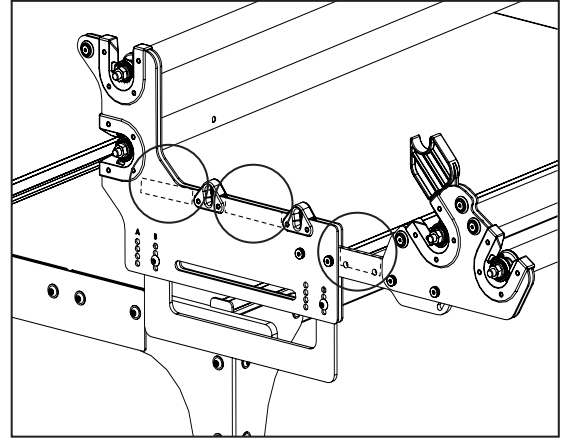



Fig. 13-1

13-2: Follow **Step 13-1** for the other remaining strip.

 **NOTE:** Handi Quilter has provided the hook and loop strips for use with clamps that have hook and loop-style straps. Only Bungee-style clamps have been provided with the HQ Studio Frame®, but these strips have been provided for use with other types of clamps.

Step 14: Bungee Clamp Assembly

Parts Needed

- 1 - frame assembly
- 4 - bungee clamps

14-1: Thread the bungee cord from the inside of the frame through the bungee slot and then pull the cord in a downward movement to lock the bungee clamp in place. (Fig. 14-1)

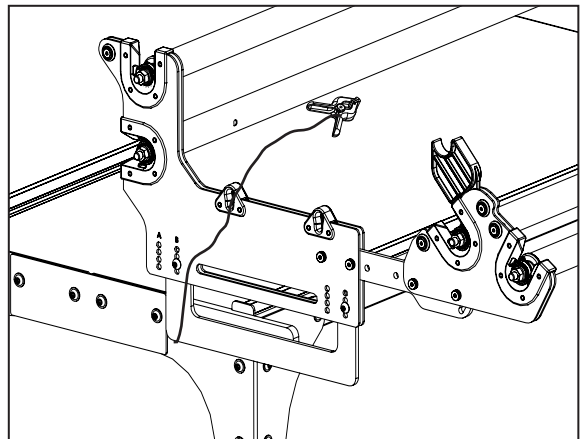

Fig. 14-1

14-2: Follow **Step 14-1** for the other three bungee clamps.

Steps 15: Hook and Loop Strip Attachment

Parts Needed

- 1 - quilt-top pole
- 1 - backing pole
- 1 - take-up pole
- 3 - hook and loop strips

Tools Required

- measuring tape or ruler (not provided)
- scissors (not provided)

15-1: Prepare to attach the hook and loop strip to the quilt top pole, backing pole, and take-up pole (see Fig. 11-1), by measuring in 3-inch from each end of the pole. Peel the backing off the strip as you go and apply to all three poles, starting at the 3-inch mark and ending at the opposite 3-inch mark.

Take care to stick the hook and loop on straight. This step will determine how well your quilts load in the future. Use the spring coupler snap buttons as a guide when aligning the hook and loop strip for best results.



NOTE: Attach the strip next to the snap button, not between.

Once the hook and loop strip has been adhered from one end of the poles to the other, it can be cut where the poles meet at each pole coupler.

Steps 16: Attach Leaders

Step 16: Attach Leaders

Parts Needed

- 1- frame assembly with hook and Loop strip applied to poles
- 3 - HQ leaders



NOTE: The leaders provided with the HQ Studio2 Frame are sized for the 12-foot frame. If you are setting the frame up permanently at the 8-foot or 4-foot length, you should cut the leaders to fit.

16-1: Mark the center of the leaders on both the hook and loop strip and the hemmed edge. Mark the center of the quilt-top pole, backing pole and take-up pole with a permanent marker.

16-2: Beginning in the center, align the marks and attach the leaders to the hook and loop strip on backing pole and the quilt top pole so the marked sides of the leaders hang to the center between the poles.

Beginning in the center, align the marks and attach the remaining leader so it falls to the back of the take-up pole.

Step 17: Adjusting HQ Studio2 Frame Height



NOTE: It is easier to raise the frame height than to lower the frame, because the legs will ratchet up when lifted. To lower the frame, a second person will be needed to release the two latches on each leg while the other lifts the frame. This is why the frame was assembled at the lowest height setting.

17-1: The frame can be all the way down with no slots showing on the legs or raised in increments up to where nine sets of slots are showing. Most quilters will have three to six sets of slots showing when the height is set comfortably for them.

17-2: Adjust the frame height so that when standing at the front of the machine with your hands on the front handle bars, your elbows are bent at a 90 degree angle. It is recommended that you raise the frame one or two slots at a time until you reach your desired height setting as described in **Steps 17-3** and **17-4**.

17-3: Place a foot on the side leg bottom tube and lift the end of the frame up until the latches click once or twice, making sure both latches are fully engaged and in the same height slot. The end of the latch levers will be about 1.5-inch away from the leg when engaged properly and much closer if not fully engaged.

17-4: Repeat **Step 17-3** on the other end of the frame and then lower the two middle legs to the same slot, ensuring that the latches are fully engaged into the same slot on both side legs and the two middle legs. You may need a second person to lift the middle of the table to engage the latches fully on the middle legs.

17-5: Finally double-check to make sure the frame is level. The slots on the legs are for rough height adjustment and the levelers on each leg are for fine height adjustment and leveling of the frame. See **Step 4-10**, if needed, for leveling review.

17-6: Your HQ Studio2 Frame is now complete.

Using the Pole Cradles

To use the HQ Pole Cradles when loading the quilt and quilt batting

1. After loading the quilt backing and the quilt top, release the ratchets on the quilt-top pole.
2. Pull one side of the quilt-top pole out of the pole bracket and lay it in the corresponding pole cradle. Repeat on the other side of the quilt frame.
3. Lay the quilt batting on the quilt backing, align it with the top of the backing, and smooth it in place.
4. Unroll enough of the quilt top to reach the top of the quilt backing and batting.
5. Return both sides of the quilt-top pole to the pole brackets and put the ratchets back in place.
6. Proceed with stitching the plumb line, aligning the quilt top with the plumb line, basting the top edge and sides of the quilt top and attaching the clamps.

To use the HQ Pole Cradles when advancing the quilt

1. When you're ready to advance your quilt, release the ratchets on the poles. Advance the quilt.
2. Pull one side of the quilt-top pole out of the pole bearing and lay it in the corresponding pole cradle. Repeat on the other side of the quilt frame.
3. Reach under the quilt top to smooth and straighten the batting.
4. Return both sides of the quilt-top pole to the pole brackets and put the ratchets back in place.
5. Proceed with smoothing and tensioning the quilt top, basting down the sides of the quilt and attaching the clamps.





Designed by a Quilter, for Quilters.®

Handi Quilter, Inc.
501 N 400 W
North Salt Lake, Utah 84054

www.HandiQuilter.com

©Handi Quilter 2018